



 **GOYEN**

# FLANGED VALVES

# GOYEN 'FS' SERIES

## PULSE JET VALVES



FS Series

### DESCRIPTION

Very high performance diaphragm valve with flanged inlet port and slide seal outlet port for easy valve installation and removal. Available with integral pilot or as remotely piloted valve. Outlet at 90° to inlet.

### SUITABLE FOR

Dust collector applications, in particular for reverse pulse jet filter cleaning and its variations, including bag filters, cartridge filters and envelope filters, ceramic filters and sintered metal fibre filters.

### CONSTRUCTION

**Body:** Diecast aluminium or 316 stainless steel

**Ferrule:** 305 SS

**Armature:** 430FR SS

**Seals:** Nitrile or Viton

**Spring:** 304 SS

**Screws:** 302 or 304 SS

**Outlet Slide Seal:** EPDM or Viton

**Diaphragm Seat:** PA-66 (standard), Viton coated mild steel

Refer to Q Series Solenoid product data sheet for solenoid construction details.

### OPERATION

**Recommended**

**on-time range:** 50–500 ms

**Recommended time**

**between pulses:** 1 minute or greater

### MAINTENANCE

Before conducting any maintenance activity on the system ensure that components are fully isolated from pressure and power supplies. Pressure and power should not be reapplied until the valve has been fully assembled.

Diaphragm and pilot inspection should be conducted annually.

### APPROVALS

- Atex II 2D Mechanical (RCA Only)
- CSA [C, US] [C22.2 No 139-10 and UL 429:2009] [CA & RCA]
- C-Tick [CA]

- EMC 2004/108/EC [CA]
- Low Voltage Directive 2006/95/EC [CA]

### INSTALLATION

1. Prepare inlet flanges and blowtube pipes to suit valve specification. Avoid installing valves underneath the tank.
2. Ensure tank and pipes are free from dirt, rust or other particulate.
3. Ensure supply air is clean and dry.
4. Mount valves to inlet flange and blowtube to valves with all seals in place. Tighten flange bolts to 10Nm (7.4 ft-lbs) Ensure blowtube is pushed all the way into the valve outlet.

5. Tanks and pipes must be independently supported from valve.
6. Make electrical connections to solenoid or connect RCA pilot port to pilot valve (RCA valves only).
7. Apply moderate pressure to system and check for installation leaks.
8. Fully pressurise system.
9. Test fire and listen for proper actuation and crisp pulse noise.

**Valve is not a structural component. Do not rely on valve to retain tanks or pipe.** Where used, refer to DEINC-002 product specification for installation details.

SIZE	OD mm	OD inches
1.5"	48.3	1.900

We recommend Schedule 40 thickness.

### WEIGHTS

SIZE	INTEGRAL PILOT (CA) kg (lb)	REMOTE PILOT (RCA) kg (lb)
45	1.830 (4.03)	1.610 (3.55)

### MAINTENANCE KITS

MODEL	NITRILE	VITON	INCLUDES
CA/RCA45FS	K4502	K4503 K4542 (Viton/SS) K4544 (Viton/SS) Main Diaphragm only	Diaphragm kits include main and secondary diaphragms and all springs.
CAC45FS to CA45FS Integral pilot cover conversion kit	K4532(NPT) K4538(RC)	K4537(NPT) K4539(RC)	The complete CA integrally piloted valve cover assembly. Does not include cover bolts or main bleed pin.
RCAC45FS to RCA45FS Remote pilot cover conversion kit	K4533(RC) K4535(NPT)	K4534(RC) K4536(NPT) K4543 (NPT/SS)	The complete RCA remotely piloted valve cover assembly with main diaphragm and spring. Does not include cover bolts or main bleed pin.
Integral pilot repair kit (CA45FS and CAC25FS)	K0380	K0384	O-ring armature assembly, armature spring, ferrule.
Integral pilot repair kit (CAC45FS)	K0390	N/A	O-ring armature assembly, armature spring, ferrule.
45FS Outlet seal	G690864	G690864-2	Outlet seal



# GOYEN 'FS' SERIES

PULSE JET VALVES

## PRODUCT CHARACTERISTICS AND PERFORMANCE

NOM. SIZE	PORT SIZE		NUMBER OF DIAPHRAGMS	FLOW		PRESSURE RANGE	TEMPERATURE RANGE °C °(F)	
	mm	in		KV	CV		NITRILE SEALS	VITON SEALS
45	40	1.5	2	56	65	30(5)–860(125)	–40(–40) to 82(179.6)	–29(–20.2) to 232(449.6)

## ORDER CODE

**RCA 45 FS 0 1 0 301**

### Pilot type

RCA=remotely piloted  
CA=integral pilot

### Valve size

45 mm

### Pilot size

0=1/8" or CA  
1=1/4"

### Solenoid type

Coil type for CA only.  
See the RCA3 Solenoid Pilot Valves  
brochure for coil options.

### Diaphragm material

0=Nitrile  
1=Viton

### Pilot thread type (RCA), Exhaust thread (CA)

0=NPT  
1=RC  
9=NPT and stainless-steel valve body

Examples: CA45FS010-300

1.5" FS valve with nitrile seals and 220/240 V AC integral pilot with DIN socket terminals.

RCAC45FS091

1.5" FS valve with 1/8" NPT remote pilot port, stainless steel body and valve cover, and viton seals.

## DIMENSIONS

(Dimensions in mm and [inches])

CA/RCA45FS

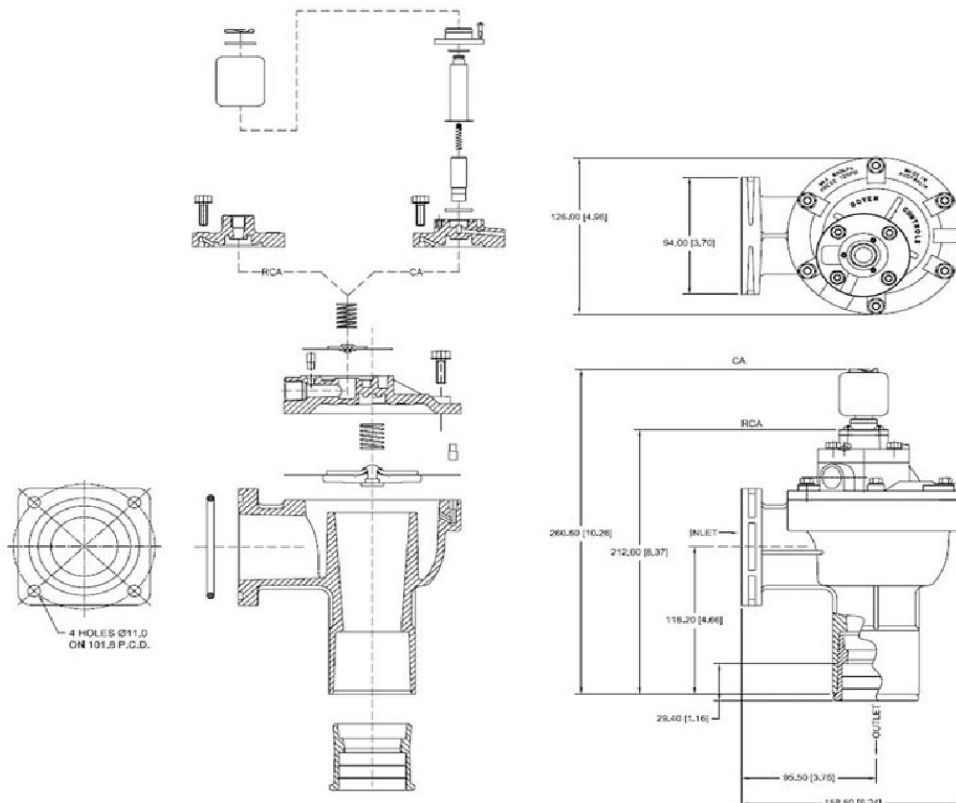

# GOYEN RCAC20FS4

REVERSE PULSE JET VALVES



## DIMENSIONS

(Dimensions in mm and [inches])

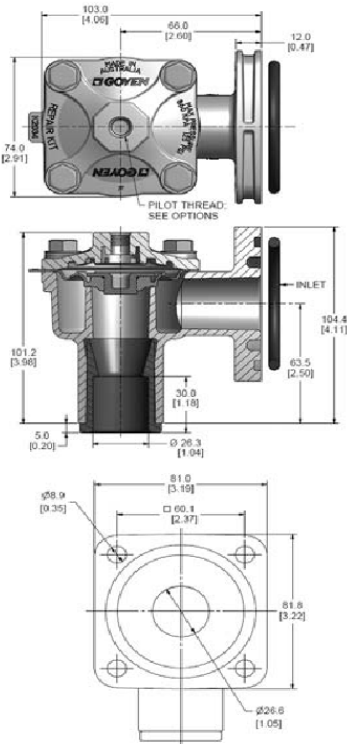

## DESCRIPTION

High-performance diaphragm valve with a flanged inlet port and slide seal outlet port. Equipped with 'Shockwave' springless diaphragm. The 4 series valves are available as remote pilot valves and may be converted to integral pilot using either the RCA3DM or RCA3PV screw-in pilots. Outlet is at 90° to inlet. The FS valve range features a larger diameter inlet providing higher performance than the DD, T or ST body styles.

## SUITABLE FOR

Dust collector applications, in particular for reverse pulse jet filter cleaning and its variations, including bag filters, cartridge filters and envelope filters, ceramic filters and sintered metal fibre filters.

## CONSTRUCTION

**Body:** Aluminium (diecast)

**Screws:** 304 Stainless steel

**Seals:**

Inlet O-ring: Nitrile used with shockwave diaphragm, Viton with Viton diaphragm

Outlet: EPDM used with shockwave diaphragm, Viton with Viton diaphragm

**Diaphragm:** Proprietary high-performance engineering thermoplastic Elastomer or Viton

**Please Note:** We recommend using Schedule 40 pipe. Thickness OD is as shown below.

SIZE	OD mm	OD inches
3/4"	26.67	1.05

## WEIGHTS

VALVE	kg (lb)
RCAC20FS4	0.51 (1.12)

## MAINTENANCE KITS

MODEL	SHOCKWAVE	VITON
<b>Diaphragm Kit</b>		
RCAC20FS4	K2034	K2033
<b>20FS4 Outlet Seal</b>		
RCAC20FS4	G690338	G690338-2

## PRODUCT CHARACTERISTICS AND PERFORMANCE

NOMINAL PORT SIZE mm (in.)	NO. OF DIAPH.	FLOW KV (CV)	PRESSURE RANGE kPa (psil)	TEMPERATURE RANGE °C (°F)	
				SHOCKWAVE	VITON
20 (3/4)	1	19 (26)	30(5) to 860(125)	-40(-40) to 82(179.6)	-29(-20.2) to 232(449.6)

## Examples:

RCAC20FS4012

3/4" FS valve with 1/8" RC pilot port threads, Shockwave diaphragm."

## Note:

1/8" Pilot available in NPT, RC and G Thread.

1/4" Pilot is only available in G Thread.

## OPERATION

**Recommended on-time range:** 50 to 500 ms

**Recommended time between pulses:**

1 minute or greater

## MAINTENANCE

Before conducting any maintenance activity on the system ensure that components are fully isolated from pressure and power supplies. Pressure and power should not be reapplied until the valve has been fully assembled.

Diaphragm and pilot unit inspection should be conducted annually.

## APPROVALS

The RCAC20FS4 meets the requirements of the European Low Voltage Directive 2006/95/EC, when fitted with the RCA3PV pilot.

## ORDER CODE

**RCAC20FS4 0 1 2**

**Pilot size**

0=1/8"

1=1/4"

**Diaphragm material**

1=Viton

2=Shockwave

**Thread type**

0=NPT

1=RC

2=G



# GOYEN RCAC25FS4

REVERSE PULSE JET VALVES



## DIMENSIONS

(Dimensions in mm and [inches])

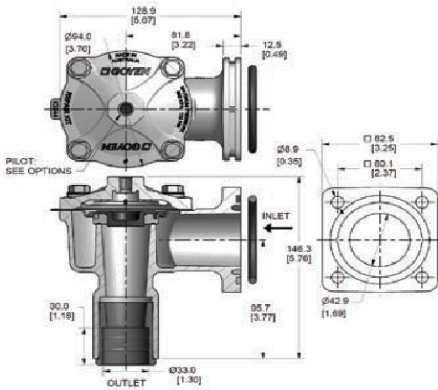

## DESCRIPTION

High-performance diaphragm valve with a flanged inlet port and slide seal outlet port. Equipped with 'Shockwave' springless diaphragm. The 4 series valves are available as remote pilot valves and may be converted to integral pilot using either the RCA3DM or RCA3PV screw-in pilots. Outlet is at 90° to inlet. The FS valve range features a larger diameter inlet providing higher performance than the DD or T body styles.

## SUITABLE FOR

Dust collector applications, in particular for reverse pulse jet filter cleaning and its variations, including bag filters, cartridge filters and envelope filters, ceramic filters and sintered metal fibre filters.

## CONSTRUCTION

**Body:** Aluminium (diecast)

**Screws:** 304 Stainless steel

**Seals:** Nitrile & EPDM or Viton

**Diaphragm:** Proprietary high-performance engineering thermoplastic Elastomer or Viton

## OPERATION

**Recommended on-time range:** 50 to 500 ms

**Recommended time between pulses:** 1 minute or greater

**Please Note:** We recommend using Schedule 40 pipe. Thickness OD is as shown below.

SIZE	OD mm	OD inches
1"	33.4	1.315

## WEIGHTS

VALVE	kg (lb)
RCAC25FS4	0.85 (1.87)

## MAINTENANCE KITS

MODEL	SHOCKWAVE	VITON
<b>Diaphragm Kit</b> RCAC25FS4	K2546	K2551
<b>FS Outlet Seal</b> RCAC25FS4	G690763	G690763-2

## PRODUCT CHARACTERISTICS AND PERFORMANCE

NOMINAL PORT SIZE mm (in.)	NO. OF DIAPH.	FLOW KV (CV)	PRESSURE RANGE kPa (psi)	TEMPERATURE RANGE °C (°F)	
				SHOCKWAVE	VITON
25 (1)	1	34 (40)	30(5) to 860(125)	-40(-40) to 82(179.6)	-29(-20.2) to 232(449.6)

## Examples:

RCAC25FS4012  
1" FS valve with 1/8" RC pilot port threads, Shockwave diaphragm.

## Note:

1/8" Pilot available in NPT, RC and G Thread.  
1/4" Pilot is only available in G Thread.

## ORDER CODE

<b>RCAC25FS4</b>	<b>0</b>	<b>1</b>	<b>2</b>
<b>Pilot size</b>	0=1/8"	1=1/4"	
<b>Diaphragm material</b>	1=Viton	2=Shockwave	
<b>Thread type</b>	0=NPT	1=RC	2=G

